

TAD570-572VE

5.13 litre, in-line 4 cylinder - 105, 129 & 160 kW

EU Stage IV / US EPA Tier 4 Final

TAD570-572VE is a powerful, reliable and economical off-road Diesel Engine range built on the proven Volvo Group in-line four concept.

Low cost of ownership

World class fuel efficiency combined with a reliable exhaust aftertreatment system gives high uptime as well as low cost of ownership. No downtime for regeneration or decreased service intervals.

Compact & simple installation

SCR technology selected by Volvo does not increase amount of cooling capacity needed. As optional equipment all material needed in order to install the engine can be ordered from Volvo Penta. Installation guidelines as well as drawings and CAD models are easy to access. The result is an engine and aftertreatment system that is easy to install.

Durability & low noise

Long experience with SCR systems in combination with base engine development reduces risk of downtime. Well-balanced to produce smooth operation with low noise.

Power & torque

Maximum power and torque available at low rpm. As a result noise as well as fuel consumption is very low. Useful engine speed for the TAD570-572VE is due to power and torque layout very flexible.

Low exhaust emission

Efficient injection as well as robust engine design in combination with optimised SCR technology and a cooled EGR contributes to excellent combustion and low fuel consumption.

Easy service & maintenance

Easily accessible service and maintenance points contribute to the ease of service of the engine. As optional equipment possible to remote mount filters and service points. Up to 1000 hour oil change interval.



- Proven and straight-forward design - built on Volvo Group technology
- Low cost of ownership and operation
- High power and torque already at low engine speed
- SCR and cooled EGR only - no DPF, DOC or regeneration
- Compact, simple installation and easy to service
- Similar engine footprint for all emission standards
- Wide range of optional equipment

Technical description

Engine and block

- Cast iron cylinder block
- Replaceable cylinder liners
- Replaceable valve guides and valve seats
- Overhead camshaft and four valves per cylinder

Lubrication system

- Full flow cartridge insert filter
- Gear type lubricating oil pump, gear driven

Fuel system

- Common rail
- Gear driven fuel feed pump
- Fuel prefilter with water separator and water-in-fuel indicator / alarm
- Fine fuel filter of cartridge, insert type
- Manual feed pump on pre filter

Cooling system

- Belt driven coolant pump with high degree of efficiency

Turbo charger

- Variable Geometry Turbo (VGT)

Electrical system

- Engine Management System (EMS) 2.3, an electronically controlled processing system which optimizes engine performance. It also includes advanced features for diagnostics and fault tracing.
- The instruments and controls connect to the engine via the CAN SAE J1939 interface. Options available for engine control equipment.

Exhaust aftertreatment system

- SCR and cooled EGR only
- Airless urea injection
- Wide range of options available, including different sized AdBlue® / DEF tanks (also possible for OEM to design own tank).

**VOLVO
PENTA**

TAD570-572VE

Technical data

Engine designation TAD570-572VE
 Configuration and no. of cylinders in-line 4
 Displacement, l (in³) 5.13 (313)
 Method of operation 4-stroke
 Direction of rotation (viewed towards flywheel) anti-clockwise
 Bore, mm (in.) 110 (4.33)
 Stroke, mm (in.) 135 (5.31)
 Compression ratio 17.5:1
 Dry weight, engine only, kg (lb) 556 (1226)

Engine	kW	Hp	rpm	Max Nm
TAD570VE	105	143	2300	710
TAD571VE	129	175	2300	810
TAD572VE	160	2300	910	

Main components - principal layout

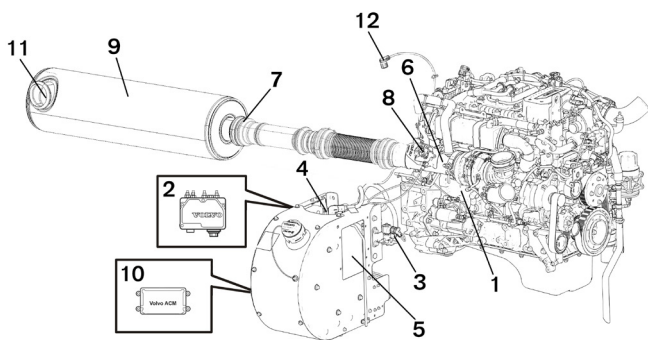

- 1. Engine
- 2. Pump unit
- 3. Solenoid valve, heating/cooling
- 4. AdBlue / DEF level sensor
- 5. AdBlue / DEF solution tank
- 6. NOx sensor
- 7. Temperature sensor exhaust
- 8. Dosage Valve
- 9. Muffler with catalytic converter
- 10. Aftertreatment control module
- 11. NOx sensor
- 12. Temperature sensor air

Dimensions

Not for installation. Dimensions in mm.

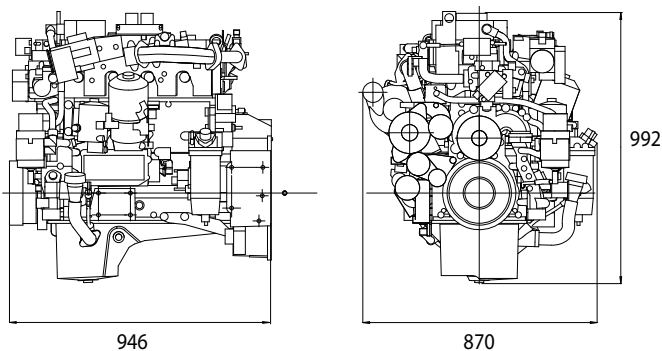

Power, kW

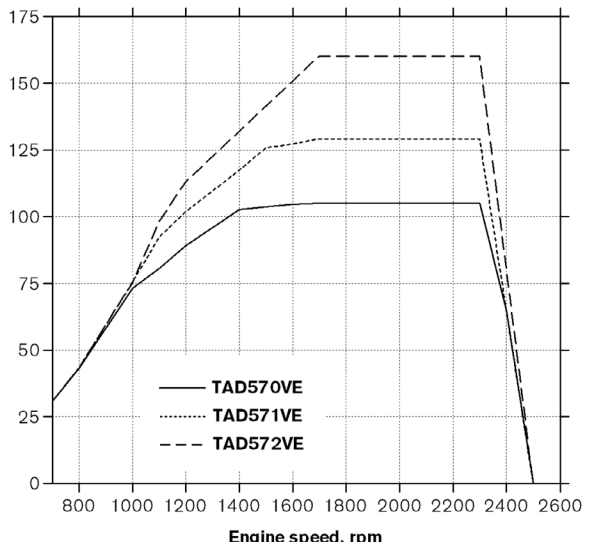

Torque, Nm

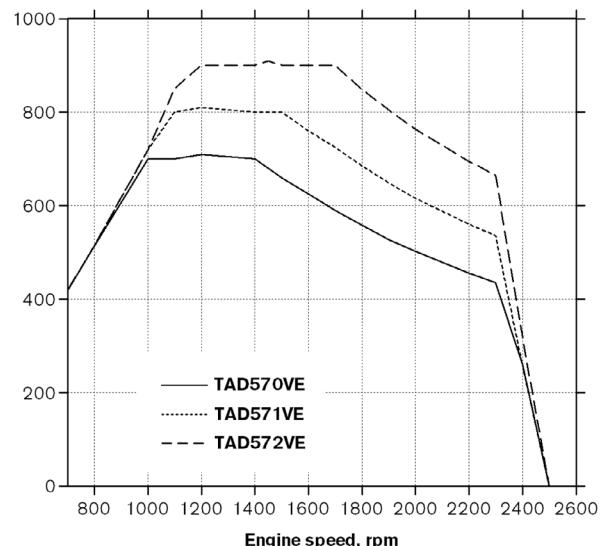

Fuel consumption, g/kWh

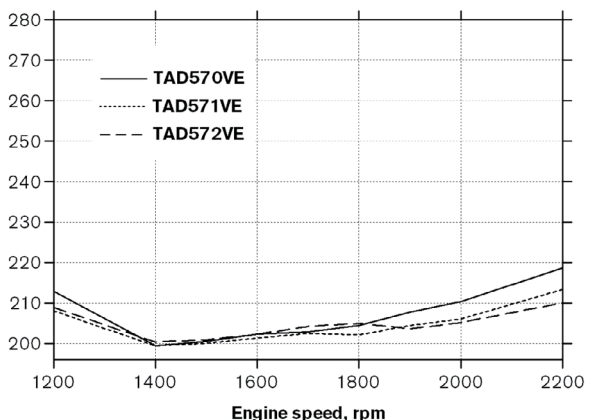

Power standards

The engine performance corresponds to ISO 3046, BS 5514 and DIN 6271. The technical data applies to an engine without cooling fan and operating on a fuel with calorific value of 42.7 MJ/kg (18360 BTU/lb) and a density of 0.84 kg/litre (7.01 lb/US gal, 8.42 lb/Imp gal), also where this involves a deviation from the standards.

Additional information

For additional information, please contact your Volvo Penta representative or visit www.volvopenta.com.

Not all models, standard equipment and accessories are available in all countries. All specifications are subject to change without notice. The engine illustrated may not be entirely identical to production standard engines.

VOLVO PENTA

AB Volvo Penta

SE-405 08 Göteborg, Sweden
www.volvopenta.com