

D7A TA

7,15 litre, in-line 6 cylinder - Constant engine speed

139 kWm at 1500 rpm & 148 kWm at 1800 rpm

IMO NOx Tier II and CCNR2

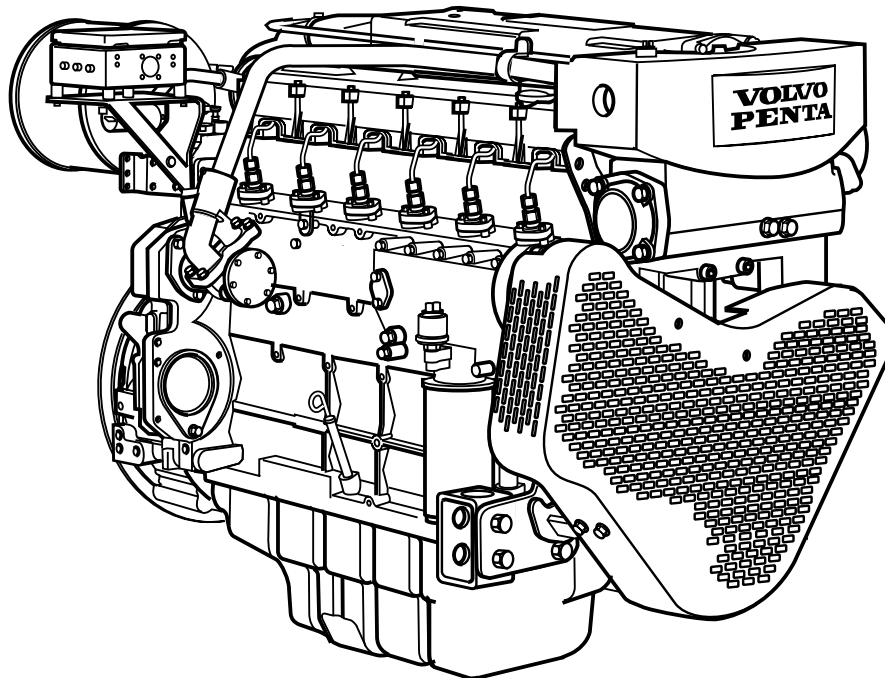

D7A TA is a reliable, type-approved, marine diesel engine. It's designed by Volvo Penta to power a wide range of marine auxiliary applications.

The rigid in-line 6 cylinder block has a high-pressure injection system with single injection pumps and a six-hole injection nozzles that operate under high pressure. In combination with the turbo and charge-air-cooler, the engine features fast response to load variations, low fuel consumption and low emission levels. The robust design, including a stable engine block and over-sized crankshaft bearings provide smooth operation and low noise.

Typical applications:

- Gensets
- Diesel electric applications
- Pumps
- Cranes
- Hydraulic power packs
- Air compressors
- Fire-fighting equipment

The compact and space saving design makes for easy installation and easily accessible service points.

- Rigid and robust design
- Fuel-efficient and low emission levels
- High load acceptance
- Low weight, noise and vibrations
- Type-approved
- Classifiable by all major societies
- Compact installation and easy to service

The engine can be equipped with a wide range of optional equipment and is available with Heat Exchanger (HE) and Keel Cooled (KC) cooling system. The engine and equipment can be covered with the Extended Coverage which prolongs the standard warranty up to five years - or the corresponding number of running hours.

D7A TA

Technical Data

General

Engine designation	D7A TA
Displacement, litre (in ³)	7,15 (437)
Configuration and number of cylinders	in-line 6
Method of operation	4-stroke, direct-injected, turbocharged diesel engine with charge air cooler
Bore/stroke, mm (in.)	108/130 (4.25/5.12)
Compression ratio	17.5
Dry weight bobtail HE ¹⁾ , kg (lb)	760 (1676)
Dry weight bobtail KC ²⁾ , kg (lb)	740 (1631)
Flywheel housing/SAE size	11.5" flywheel with SAE 2 housing

Performance, fuel & emissions

Engine speed	1500 rpm	1800 rpm	
Crankshaft power HE, kW	139	148	
Crankshaft power KC, kW	139	148	
Spec.fuel.consump., g/kWh	at 50% load	213	220
	at 75% load	208.5	212
	at 100% load	208.5	213
Emission compliance	IMO NOx Tier II	IMO NOx Tier II	
	CCNR2	CCNR2	

Recommended fuel to conform to ASTM-D975 1-D and 2-D, EN 590 or JIS KK 2204

10% overload available acc. to class requirements. Fuel temperature 40°C (104°F). Technical data according to ISO 3046 Fuel Stop Power with a tolerance ±4%. Fuel with a lower calorific value of 42700 kJ/kg and density of 840 g/liter at 15°C (60°F). Merchant fuel may differ from this specification which will influence engine power output and fuel consumption.

¹⁾ Heat Exchanger cooled system (HE), ²⁾ Keel Cooled system (KC)

D7A TA

Technical description

Engine and block

- Cylinder block, head and flywheel housing made of cast iron
- Belt guard
- 11.5" flywheel with SAE 2 housing
- Nitrocarburized transmission gears
- Press-hardened crankshaft
- Forged aluminum pistons
- Cylinder liners of wet type
- Exhaust elbow, dry, with integrated flexible compensator

Lubrication system

- Oil filler in valve cover
- Manual oil drain pump
- Lubrication oil pump of rotor type
- Freshwater-cooled oil cooler
- Full flow oil filters of spin-on type
- Closed crankcase ventilation system

Fuel system

- Fuel feed pump
- Jacketed fuel pipes
- Fine fuel filter of spin-on type
- Unit pumps
- Six-hole injectors
- Mechanical governor with smoke delimitter
- Fuel stopping solenoid 24V

Heat Exchanger cooled system (HE)

- For seawater-cooled engines

- V-belt-driven freshwater pump
- Gear-driven seawater pump
- Engine-mounted tubular heat exchanger with integrated expansion tank

Keel cooled system (KC)

- 2-circuit keel cooling system
- Gear-driven pump (LT circuit)
- Belt-driven pump (HT circuit)
- Engine-mounted expansion tank (HT circuit)

Optional equipment

Engine

- Twin oil filter with change over valve
- GAC electronic governor
- Single or twin fuel/water separating pre filter
- Twin fuel filters
- Silencer, dry, with or without spark arrestor
- Electrical or air starting systems available
- Kit to connect both HT and LT together into a 1.5-circuit system including engine mounted expansion tank

Non classified control system

- 2-pole 24V system including:
 - Oil pressure shutdown
 - Oil pressure gauge (optional)
 - Coolant temp shutdown
 - Coolant temp gauge (optional)
 - Coolant level shutdown
 - Overspeed shutdown

- Battery charging alarm
- Rpm gauge
- Hour counter
- Instrument panel for second control station
- Extension cables in different lengths

Classified control and monitoring system MCC

- Alarm and monitoring functions according to classification
- Optional functions on request
- Modbus
- Configurable inputs and outputs
- SDU, shutdown unit, includes all shutdown functions required by classification societies

Miscellaneous

- Engine heater 230V/820W
- Batteries 14V/140A
- Battery charger
- Synchronization unit (for GAC system)
- Load sharing unit (for GAC system)
- 2-pole 28V/55A alternator
- Spare parts according to classification recommendations

Dimensions

Not for installation, mm (in.)

Engine with HE (illustrated) & KC

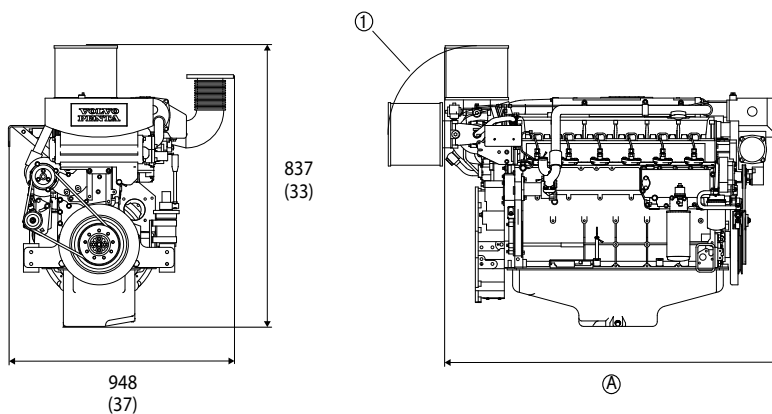

Ⓐ HE 1409 (55) KC 1285 (50)

① Adjustable position.

Volvo Penta is part of the Volvo Group, the world's leading manufacturer of trucks, buses, construction equipment and diesel engines. Volvo Penta has approximately 4,000 dealers in some 130 countries.

For further information, please contact your local Volvo Penta dealer or visit www.volvopenta.com.

Not all models, standard equipment and accessories are available in all countries. All specifications are subject to change without notice. The engine illustrated may not be entirely identical to production standard engines.

VOLVO PENTA

AB Volvo Penta

SE-405 08 Göteborg, Sweden
www.volvopenta.com