

IPS1050



General Data

System designation	IPS1050
Engine displacement, l (in ³)	12.8 (780)
Configuration	in-line 6
Crankshaft power, kW (hp)	588 (800) @ 2300 rpm
Propshaft power, kW (hp)	564 (768) @ 2300 rpm
Aspiration	Dual stage turbo with twin charge air coolers
Rating	4*
Package weight, kg (lb)	2300 (5060)
Propeller series	Q1-Q7, QS5, QE1-4
Voltage	24V
Emission compliance	IMO NOx, EU RCD Stage II, US EPA Tier 3
Type approval	DNV
Application	Twin/multiple engine installation in planing hulls
Speed range	26 to 40 knots

Technical data according to ISO 8665. With fuel having an LHV of 42700 kJ/kg and density of 840 g/liter at 15 °C (60 °F). Merchant fuel may differ from this specification which will influence engine power output and fuel consumption.

*RATING 4. For light planing craft in commercial operation

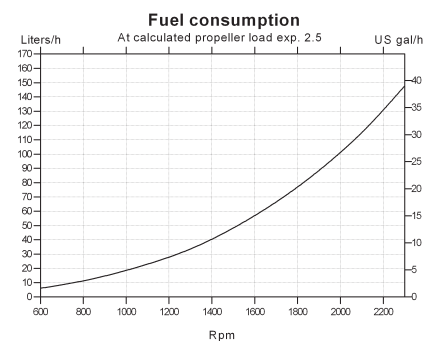
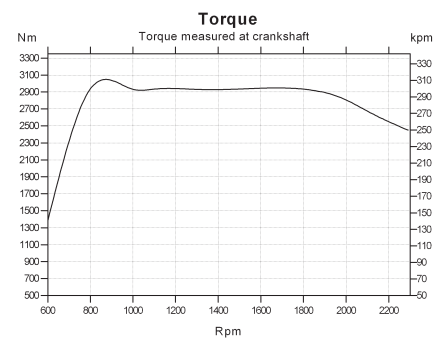
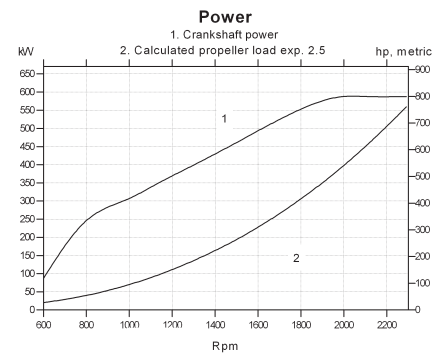

**VOLVO
PENTA**

IPS1050

Technical description:

Engine and block

- Cylinder block made of cast iron
- One-piece cast-iron cylinder head
- Ladder frame fitted to engine block
- Replaceable wet cylinder liners and valve seats/guides
- Drop forged crankshaft with induction hardened bearing surfaces and fillets with seven main bearings
- Four-valve-per-cylinder layout with overhead camshaft and center position of unit injectors
- Each cylinder features cross-flow inlet and exhaust ducts
- Gallery oil-cooled cast aluminum alloy pistons with three piston rings
- Rear-end transmission

Engine mounting

- Flexible engine mounting

Lubrication system

- Integrated oil cooler in cylinder block
- Rear positioned twin full flow oil filter of spin-on type and by-pass filter

Fuel system

- Electronic high pressure unit injectors
- Gear-driven fuel pump and injection timing
- Electronically controlled central processing system (EMS – Engine Management System)
- Single fine fuel filter of spin-on type

Air inlet and exhaust system

- Twin turbo technology with freshwater-cooled charge air cooler
- Air filter with replaceable inserts
- Wet exhaust elbow (option)

Cooling system

- Seawater-cooled plate heat exchanger
- Coolant system prepared for hot water outlet
- Easily accessible seawater pump in rear end of flywheel housing

Electrical system

- 24V/110A plus an optional extra 24V/110A alternator

Instruments/controls (option)

- Complete instrumentation including key switch and interlocked alarm
- EVC monitoring panels
- Electronic shift and throttle
- Plug-in connectors
- EVC system color display

Dimensions IPS1050

Not for installation

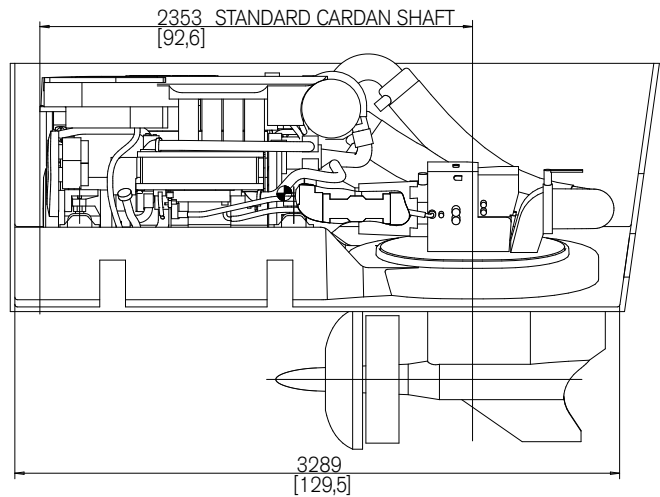
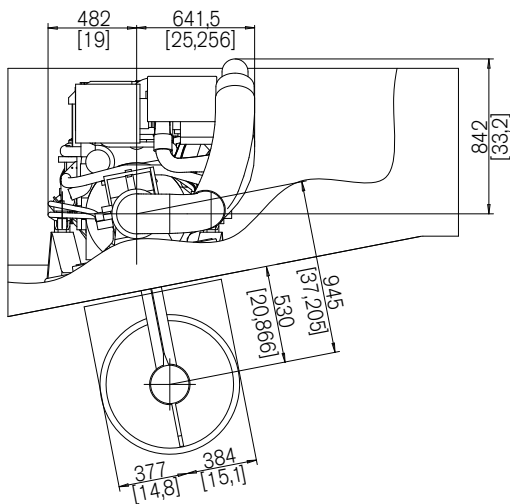

More information

Contact your local Volvo Penta dealer for more information regarding Volvo Penta engines and optional equipment/accessories or visit www.volvopenta.com



Download the Volvo Penta dealer locator App for your iPhone or Android

VOLVO PENTA

AB Volvo Penta

SE-405 08 Göteborg, Sweden
www.volvopenta.com

Not all models, standard equipment and accessories are available in all countries. All specifications are subject to change without notice. The engine illustrated may not be entirely identical to production standard engines.