

# TAD840GE

7.7 liter, in-line 6 cylinder

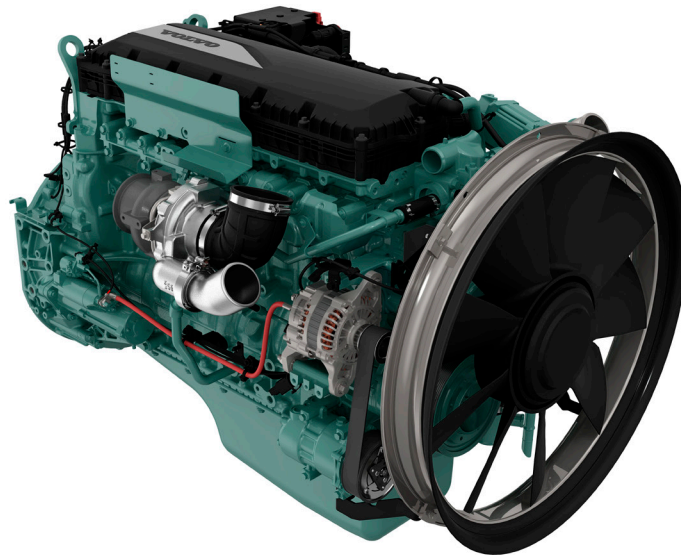

The TAD840GE is a powerful, reliable and economical Generating Set Diesel Engine built on the dependable in-line six design.

### Durability & low noise

Designed for easiest, fastest and most economical installation. Well-balanced to produce smooth and vibration-free operation with low noise level.

To maintain a controlled working temperature in cylinders and combustion chambers, the engine is equipped with piston cooling. The engine is also fitted with replaceable cylinder liners and valve seats/guides to ensure maximum durability and service life of the engine.

### Low exhaust emission

The state of the art, high-tech injection and charging system with low internal losses contributes to excellent combustion and low fuel consumption.

The TAD840GE complies with EU Stage II exhaust emission regulations.

### Easy service & maintenance

Easily accessible service and maintenance points contribute to the ease of service of the engine.

- Electronic governing EMS 2.3
- CAN bus communication
- Compact design for the power class
- High power to weight ratio
- Emission compliant acc. to EU Stage II
- Noise optimized engine design
- RoHS2 Compliant
- Dual speed

## 50 Hz/1500 rpm

Prime power			Standby power		
kWm	kWe	kVA	kWm	kWe	kVA
220	202	253	242	223	278

## 60 Hz/1800 rpm

Prime power			Standby power			Gen. eff. %
kWm	kWe	kVA	kWm	kWe	kVA	
225	207	259	248	228	285	92

Technical Data applies to an engine with fan.

# TAD840GE

7.7 liter, in-line 6 cylinder

## Technical description

### Engine and block

- Optimized cast iron cylinder block with optimum distribution of forces
- Piston cooling for low piston temperature and reduced ring temperature
- Drop forged steel connecting rods
- Crankshaft hardened bearing surfaces and fillets for moderate load on main and big-end bearings
- Keystone top compression rings for long service life
- Replaceable valve guides and valve seats
- Lift eyelets
- Flywheel housing with connection according to SAE 1 and SAE 2
- Flywheel for flexplate
- Fixed integrated radiator front engine suspension
- Transport brackets, rear

### Lubrication system

- Full flow cartridge insert filter
- Rotary displacement oil pump driven by the crankshaft
- Deep front oil sump
- Oil filler on top
- Oil dipstick, short in front
- Integrated full flow oil cooler, side-mounted

### Fuel system

- Common rail
- Gear driven fuel feed pump
- Six hole fuel injection nozzles
- Electronic governor
- Fuel prefilter with water separator
- Fine fuel filter of cartridge insert type

### Intake and exhaust system

- Connection flange for exhaust line
- Waste gate turbo charger, center low with exhaust flange
- Two-stage air filter, with cyclon
- Heater flange in charge air inlet (with relay)

### Cooling system

- Belt driven, maintenance-free coolant pump with high degree of efficiency
- Efficient cooling with accurate coolant control through a water distribution duct in the cylinder block
- Reliable thermostat with minimum pressure drop
- Pusher fan

### Electrical system

- Engine Management System 2 (EMS 2.3), an electronically controlled processing system which optimizes engine performance. It also includes advanced facilities for diagnostics and fault tracing.
- Sensors for oil pressure, boost pressure, boost temp, exhaust temp, coolant temp, water in fuel, fuel pressure and two speed sensors.

## Technical data

Configuration and no. of cylinders .....	in-line 6
Displacement, l (in <sup>3</sup> ) .....	7.7 (470)
Method of operation .....	4-stroke
Bore, mm (in.) .....	110 (4.33)
Stroke, mm (in.) .....	135 (5.31)
Wet weight, engine only, kg (lb) .....	737 (1625)

## Fuel consumption, g/kWh (lb/hph)

	Prime Power		Standby Power	
	1500 rpm	1800 rpm	1500 rpm	1800 rpm
25%	227 (0.368)	244 (0.396)	223 (0.361)	236 (0.383)
50%	202 (0.327)	211 (0.342)	201 (0.326)	208 (0.337)
75%	201 (0.326)	208 (0.337)	200 (0.324)	208 (0.337)
100%	200 (0.324)	207 (0.336)	203 (0.329)	205 (0.332)

## Dimensions

Not for installation. Dimensions in mm.

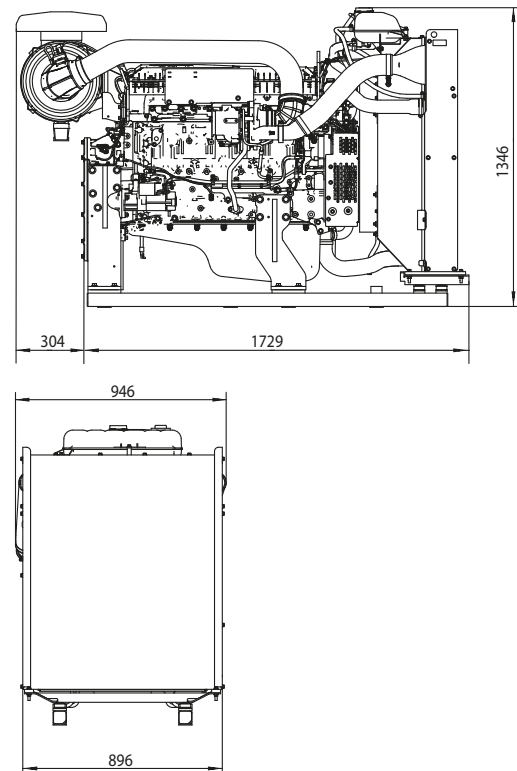

## Rating guidelines

PRIME POWER rating corresponds to ISO Standard Power for continuous operation. It is applicable for supplying electrical power at variable load for an unlimited number of hours instead of commercially purchased power. A10 % overload capability for governing purpose is available for this rating.

STAND-BY POWER rating corresponds to ISO Standard Fuel Stop Power. It is applicable for supplying stand-by electrical power at variable load in areas with well established electrical networks in the event of normal utility power failure. No overload capability is available for this rating.

1 kW = 1 hp x 1.36  
1 hp = 1 kW x 0.7355

## Power standards

The engine performance corresponds to ISO 3046, BS 5514 and DIN 6271. The technical data applies to an engine without cooling fan and operating on a fuel with calorific value of 42.7 MJ / kg (18360 BTU/lb) and a density of 0.84 kg/liter (7.01 lb/US gal), also where this involves a deviation from the standards. Power output guaranteed within 0 to +2% att rated ambient conditions at delivery. Ratings are based on ISO 8528. Engine speed governing in accordance with ISO 8528-5.

Please contact your local Volvo Penta dealer for further information. Please note that products illustrated may differ from production models. Not all models and accessories are available in all markets, and standard equipment may vary between different markets. Every effort has been made to ensure that facts and figures are correct at the time of publication. However, Volvo Penta reserves the right to make changes without prior notice at any time.

# VOLVO PENTA

AB Volvo Penta

SE-405 08 Göteborg, Sweden  
www.volvopenta.com