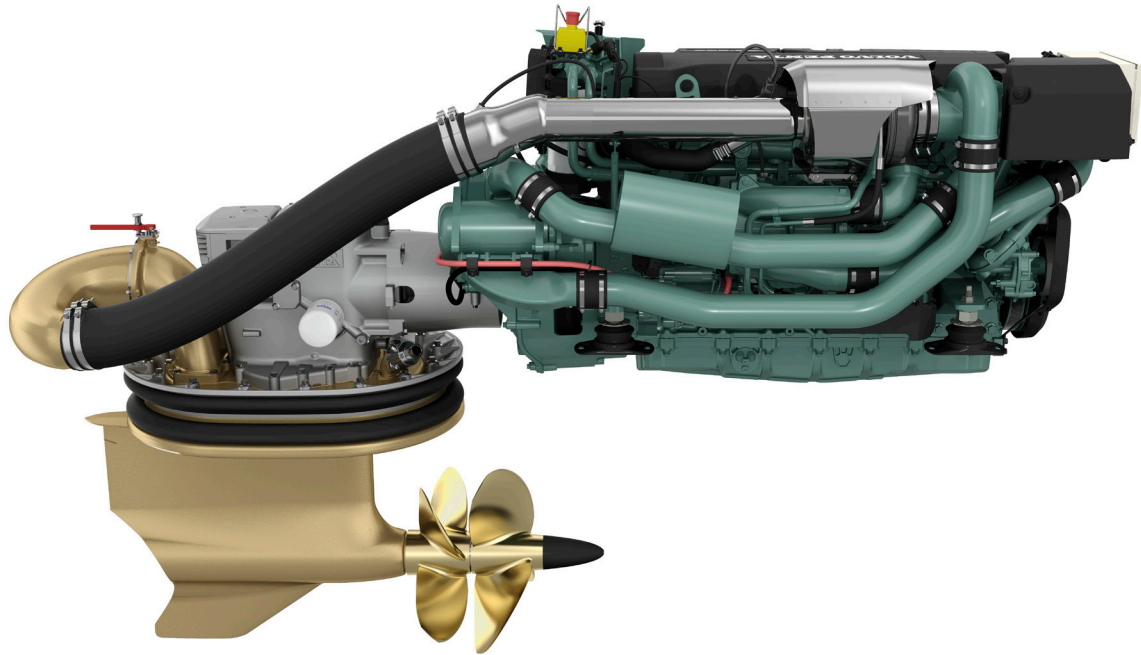

IPS650/800

NEW!

General Data

	IPS650	IPS800
System designation	IPS650	IPS800
Engine displacement, l (in ³)	10.84 (661.3)	10.84 (661.3)
Configuration	in-line 6	in-line 6
Crankshaft power, kW (hp)	375 (510) @ 2250 rpm	459 (625) @ 2400 rpm
Propshaft power, kW (hp)	354 (482) @ 2250 rpm	435 (591) @ 2400 rpm
Aspiration	Twin entry turbo and compressor	
Rating	R3*	R4**
Package dry weight, approx. kg (lb)	1800 (3968)	1800 (3968)
Propeller series	P2-P8, PS4-PS5	P2-P8, PS4-PS5
Voltage	24V	24V
Emission compliance	IMO NO _x , EU RCD Stage II, US EPA Tier 3	
Application	Twin/multiple engine installation in planing hulls	
Speed range	22 to 40 knots	

Technical data according to ISO 8665. With fuel having an LHV of 42700 kJ/kg and density of 840 g/liter at 15°C (60°F). Merchant fuel may differ from this specification which will influence engine power output and fuel consumption.

***RATING 3.** For commercial vessels or craft with high demands on speed and acceleration, planing or semi-planing hulls in cyclical operation.

****RATING 4.** For light planing craft in commercial operation

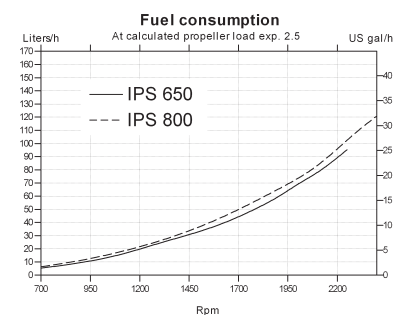
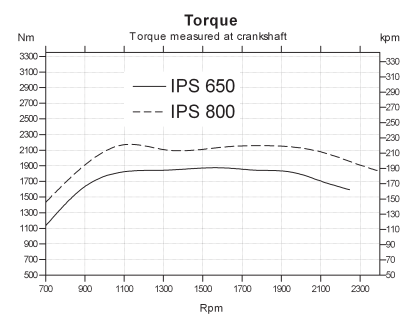
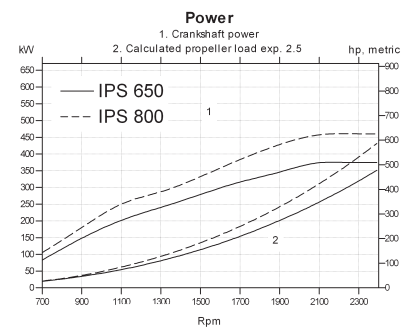
**VOLVO
PENTA**

IPS650/800

Technical description:

Engine and block

- Cylinder block made of cast iron
- One-piece cast-iron cylinder head
- Ladder frame fitted to engine block
- Replaceable wet cylinder liners and valve seats/guides
- Drop forged crankshaft with induction hardened bearing surfaces and fillets with seven main bearings
- Four-valve-per-cylinder layout with overhead camshaft and center position of unit injectors
- Each cylinder features cross-flow inlet and exhaust ducts
- Gallery oil-cooled cast aluminum alloy pistons with three piston rings
- Rear-end transmission

Engine mounting

- Flexible engine mounting (option)

Lubrication system

- Integrated oil cooler in cylinder block
- Symmetrically positioned twin full flow oil filter of spin-on type and by-pass filter

Fuel system

- Electronic high pressure unit injectors
- Gear-driven fuel pump and injection timing
- Electronically controlled central processing system (EMS – Engine Management System)
- Single fine fuel filter of spin-on type, with water separator and water alarm

Air inlet and exhaust system

- Mid-positioned twin entry turbocharger with aftercooler
- Air filter with replaceable inserts
- Wet exhaust elbow (option)
- Loss of sea water alarm

Cooling system

- Seawater-cooled tubular heat exchanger

- Coolant system prepared for hot water outlet
- Easily accessible seawater impeller pump in rear end

Electrical system

- 24V with extra 12V/115A or 24V/80A alternator

Instruments/controls

- Complete instrumentation including key switch
- Electronic remote control for throttle and shift
- Plug-in connectors
- EVC system display (option)

Dimensions IPS650/800

Not for installation

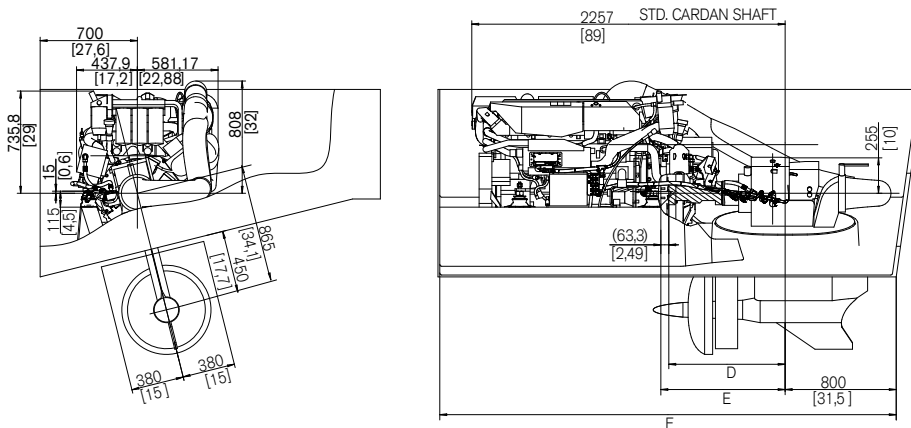

CARDAN LENGTH	D	E	F
STD 370 ± 15mm	816 ± 15	895 ± 15	3287 ± 15
700-800mm	1146-1246	1225-1325	3617-3717
1100-1200mm	1546-1646	1625-1725	4017-4117
1500-1600mm	1946-2046	2025-2125	4417-4517
1900-2000mm	2346-2446	2425-2525	4817-4917
2400-2500mm	2846-2946	2925-3025	5317-5417

More information

Contact your local Volvo Penta dealer for more information regarding Volvo Penta engines and optional equipment/accessories or visit www.volvopenta.com



Download the Volvo Penta dealer locator App for your iPhone or Android

VOLVO PENTA

AB Volvo Penta

SE-405 08 Göteborg, Sweden
www.volvopenta.com

Not all models, standard equipment and accessories are available in all countries. All specifications are subject to change without notice. The engine illustrated may not be entirely identical to production standard engines.